



elio



finiture / finishes / finitions / ausföhrungen / acabados

.015
Cromo
Chrome
Chromé
Verchromt
Cromado

.560
Nero opaco
Matt black
Noir mat
Matt schwarz
Negro mate

.345
Acciaio spazzolato
Brushed nickel
Acier brossé
Edelstahl Optik
Acero cepillado



AC0844

AC0982

EL971402

EL830101

EL860512

AC0371

EL830101

BOX PCS. 12

Kg. 2,1



Miscelatore monocomando per lavabo con scarico 1"1/4 con flex inox cm 50 att. 3/8" F.

Single lever washbasin mixer with 1"1/4 pop-up waste and 3/8" F flex. hoses cm 50.

Mitigreur de lavabo avec vidage automatique 1"1/4 et flexibles d'alimentation cm 50 3/8" F.

Einhebelmischer Waschtischbatterie mit Ablaufgarnitur 1"1/4 und flex. Anschlussschläuchen cm 50 3/8" F.

Monomando para lavabo con desagüe 1"1/4, tubo flexible inoxidable de 50 cm, empalme 3/8" F.

.015 Cromo / Chrome / Chromé / Verchromt / Cromado

.560 Nero opaco / Matt black / Noir mat / Matt schwarz / Negro mate

.345 Acciaio spazzolato / Brushed nickel / Acier brossé / Edelstahl Optik / Acero cepillado

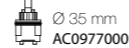
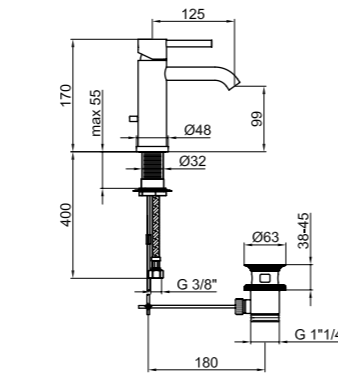

EL830102

EL830401

BOX PCS. 10

Kg. 2,7



Miscelatore monocomando per lavabo alto con scarico up & down; flex inox cm 70 att. 3/8" F.

High single lever washbasin mixer with up & down pop-up waste, with 3/8" flex. hoses 70 cm.

Mitigreur de lavabo haut avec vidage up & down, flexibles d'alimentation cm 70 3/8" F.

Einhebelmischer Waschtischbatterie, mit hoher Ausführung, mit up & down Ablaufgarnitur, mit Flex. Anschlussschläuchen cm 70 3/8" F.

Monomando para lavabo alto con valvula click-clack, tubo flexible inoxidable de 70 cm, empalme 3/8" F.

.015 Cromo / Chrome / Chromé / Verchromt / Cromado

.560 Nero opaco / Matt black / Noir mat / Matt schwarz / Negro mate

.345 Acciaio spazzolato / Brushed nickel / Acier brossé / Edelstahl Optik / Acero cepillado

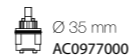
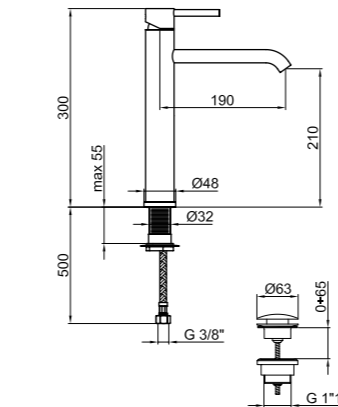

EL830402

EL830606

BOX PCS. 12

Kg. 2,1



Miscelatore monocomando per lavabo incasso muro, con piastra orizzontale, senza scarico e flessibili.

Concealed single lever washbasin mixer, horizontal cover plate, without pop-up waste and flex hoses.

Mitigreur de lavabo à encastrer, rosace horizontale, sans vidage et flexibles.

Einhebelmischer Unterputz-Waschtischbatterie waagerechte Rosette, ohne Ablaufgarnitur und flex. Anschlussschläuchen.

Monomando empotrable para lavabo, de pared, con placa horizontal, sin desagüe ni tubos flexibles.

.015 Cromo / Chrome / Chromé / Verchromt / Cromado

.560 Nero opaco / Matt black / Noir mat / Matt schwarz / Negro mate

.345 Acciaio spazzolato / Brushed nickel / Acier brossé / Edelstahl Optik / Acero cepillado

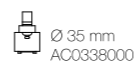
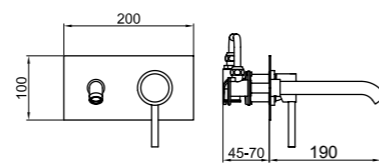

EL832101

BOX PCS. 1

Kg. 14

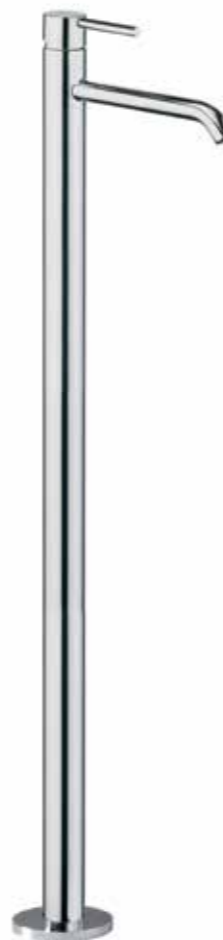

Miscelatore monocomando per lavabo a pavimento.

Single lever floor mounted basin mixer.

Mitigreur lavabo au sol.

Einhebelmischer Stand-Waschtischbatterie.

Monomando para lavabo de suelo.

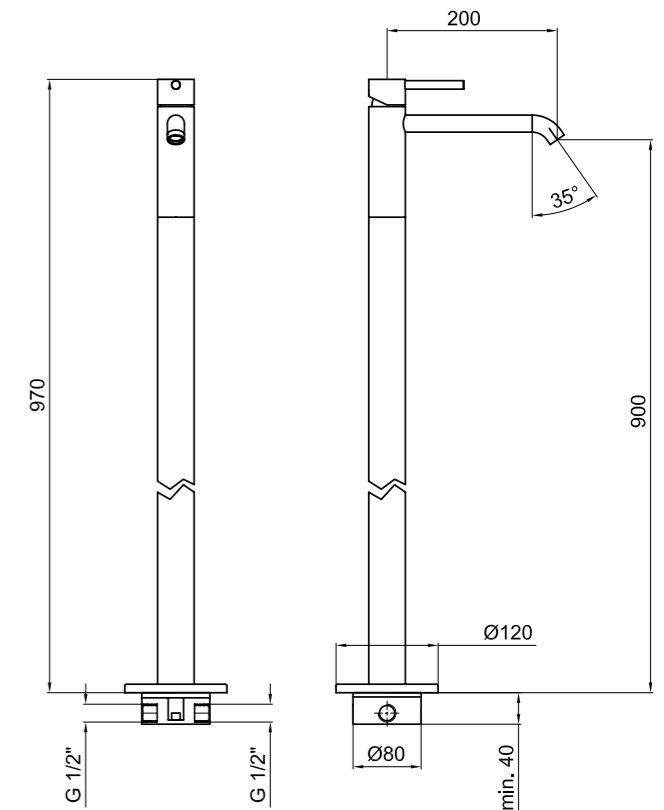

.015 Cromo / Chrome / Chromé / Verchromt / Cromado

.560 Nero opaco / Matt black / Noir mat / Matt schwarz / Negro mate

.345 Acciaio spazzolato / Brushed nickel / Acier brossé / Edelstahl Optik / Acero cepillado

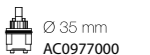

EL840101

BOX PCS. 12

Kg. 2,1



Miscelatore monocomando per bidet con scarico 1"1/4 con flex inox cm 50 att. 3/8" F.

Single lever bidet mixer with 1"1/4 pop-up waste and 3/8" F flex. hoses cm 50.

Mitigreur de bidet avec vidage automatique 1"1/4 et flexibles d'alimentation cm 50 3/8" F.

Einhebelmischer Bidetbatterie mit Ablaufgarnitur 1"1/4 und flex. Anschlussschläuchen cm 50 3/8" F.

Monomando para bidé con desagüe 1"1/4, tubo flexible inoxidable de 50 cm, empalme 3/8" F.

.015 Cromo / Chrome / Chromé / Verchromt / Cromado

.560 Nero opaco / Matt black / Noir mat / Matt schwarz / Negro mate

.345 Acciaio spazzolato / Brushed nickel / Acier brossé / Edelstahl Optik / Acero cepillado

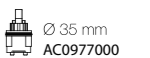
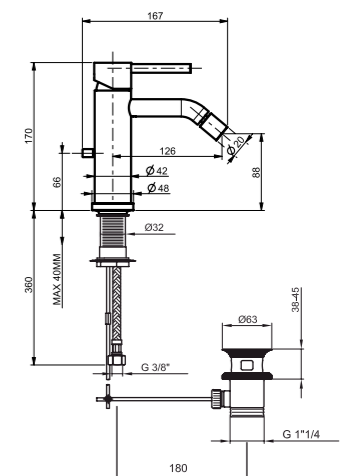

EL840102

EL850101

BOX PCS. 6

Kg. 3,2



Miscelatore monocomando per vasca esterno completo con flessibile in ottone da 150 cm doccetta multifunzione anticalcare e supporto.

Single lever bath mixer with shower set complete of brass hose 150 cm, multifunction handshower and holder.

Mitigeur bain-douche complet de flexible 150 cm, douchette multijet et support mural.

Einhebelmischer Badebatterie mit Brausegarnitur bestehend aus Metall-Brauseschlauch 150 cm, Massagehandbrause und Wandhalterung.

Monomando esterno para bañera completo, con tubo flexible de latón de 150 cm, ducha masaje antical y soporte.

.015 Cromo / Chrome / Chromé / Verchromt / Cromado

.560 Nero opaco / Matt black / Noir mat / Matt schwarz / Negro mate

.345 Acciaio spazzolato / Brushed nickel / Acier brossé / Edelstahl Optik / Acero cepillado

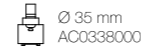
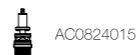
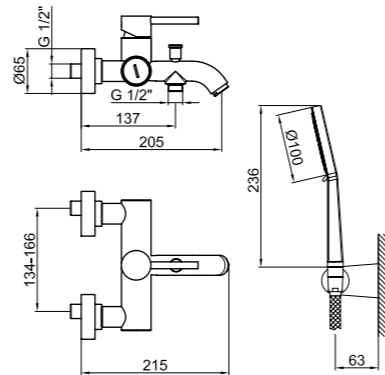

153 + € 15,00

EL850701

BOX PCS. 6

Kg. 4,5



Gruppo per bordo vasca 4 fori completo con flessibile in ottone da 150 cm e doccetta multifunzione.

4-holes deck mounted bath mixer complete of brass hose 150 cm and multifunction handshower.

Mélangeur bain-douche 4-trous, flexible 150 cm et douchette multijet.

4-Loch-Wannenrandarmatur mit Metallbrauseschlauch 150 cm und Massagehandbrause.

Grupo para borde de bañera, 4 agujeros, con tubo flexible de latón, flexibles 150 cm y ducha masaje.

.015 Cromo / Chrome / Chromé / Verchromt / Cromado

.560 Nero opaco / Matt black / Noir mat / Matt schwarz / Negro mate

.345 Acciaio spazzolato / Brushed nickel / Acier brossé / Edelstahl Optik / Acero cepillado

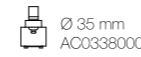
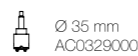
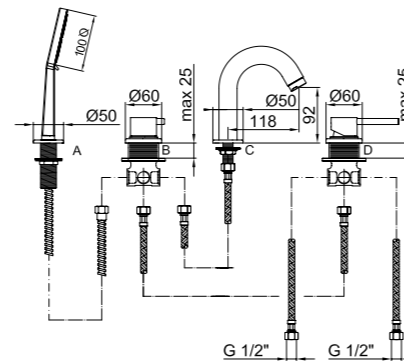

Diametro foratura pannello vasca A-B-C-D = 28 mm
Massimo spessore pannello vasca 40 mm /
Diameter of the bath deck drilling A-B-C-D = 28 mm.
Largest thickness of the bath deck 40 mm /
Diamètre perçage du bord de la baignoire A-B-C-D=28 mm.
Maximum épaisseur du bord de la baignoire 40 mm /
Bohrungsdurchmesser der Wannenrandarmatur A-B-C-D=28 mm.
Grösste Dicke der Wannenrandarmatur 40 mm /
Diámetro agujero borde de bañera A-B-C-D = 28 mm.
Máximo espesor borde de bañera 40 mm

EL851101

BOX PCS. 1

Kg. 13,00



Miscelatore monocomando per vasca a pavimento con flessibile, doccetta.

Single lever floor bath mixer with flexible hose, handshower.

Mitigeur baignoire au sol avec flexible, douchette.

Einhebelmischer Stand-Badebatterie mit Brauseschlauch, Handbrause.

Monomando para bañera de suelo, con flexible y ducha de mano.

.015 Cromo / Chrome / Chromé / Verchromt / Cromado

.560 Nero opaco / Matt black / Noir mat / Matt schwarz / Negro mate

.345 Acciaio spazzolato / Brushed nickel / Acier brossé / Edelstahl Optik / Acero cepillado

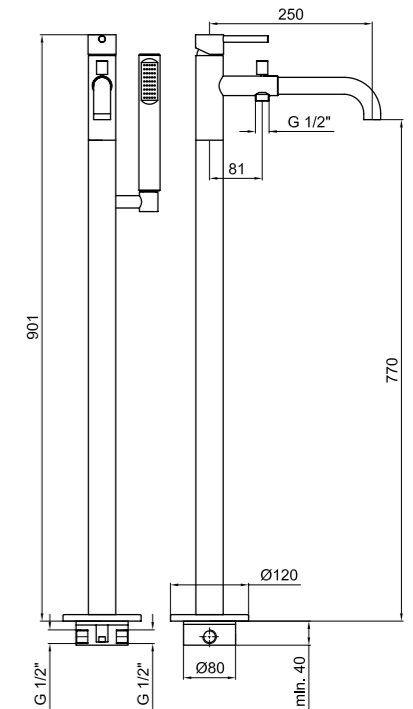

EL860101

BOX PCS. 12

Kg. 2,4



Miscelatore monocomando per vasca incasso, con deviatore, piastra orizzontale; senza flessibile doccetta e gancio di supporto.

Concealed single lever bath mixer with diverter, horizontal cover plate, without shower set.

Mitigeur bain-douche à encastrer avec inverseur, rosace horizontale, sans garniture de douche.

Einhebelmischer Unterputz-Badebatterie mit Umstellung, waagerechte Rosette, ohne Brausegarnitur.

Monomando empotrable para bañera, con desviador, placa horizontal, sin tubo flexible, ducha ni gancho de soporte.

.015 Cromo / Chrome / Chromé / Verchromt / Cromado

.560 Nero opaco / Matt black / Noir mat / Matt schwarz / Negro mate

.345 Acciaio spazzolato / Brushed nickel / Acier brossé / Edelstahl Optik / Acero cepillado

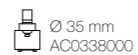
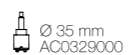
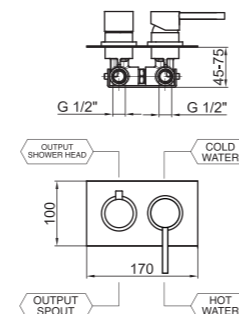

AC0371

BOX PCS. 12

Kg. 0,4



Bocca d'erogazione senza deviatore per vasca incasso; attacco da 1/2".

Spout for concealed bath mixer, 1/2" connection.

Bec pour mitigeur bain/douche encastré, attache 1/2".

Gussauslauf für Unterputz-Badebatterie, 1/2" Anschluss.

Boca de erogación sin desviador para bañera empotrable; conexión 1/2".

.015 Cromo / Chrome / Chromé / Verchromt / Cromado

.560 Nero opaco / Matt black / Noir mat / Matt schwarz / Negro mate

.345 Acciaio spazzolato / Brushed nickel / Acier brossé / Edelstahl Optik / Acero cepillado

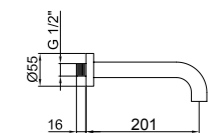

EL980507

BOX PCS. 1

Kg. 6,8

Kg. 3,2



Miscelatore termostatico per doccia esterno, versione completa di colonna, soffione e doccetta monogetto.

Thermostatic shower mixer with column, shower head and monospray handshower.

Colonne de douche thermostatique avec colonne, pomme de douche et douchette monojet.

Thermostat Brausebatterie mit Brausegleitstange, Brausekopf und 1 Funktion Handbrause.

Columna de ducha termostática, versión con columna, rociador y ducha.

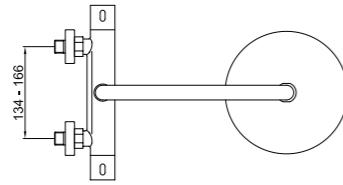

- PVC .015 Cromo / Chrome / Chromé / Verchromt / Cromado
- METAL .015 Cromo / Chrome / Chromé / Verchromt / Cromado
- .560 Nero opaco / Matt black / Noir mat / Matt schwarz / Negro mate
- .345 Acciaio spazzolato / Brushed nickel / Acier brossé / Edelstahl Optik / Acero cepillado

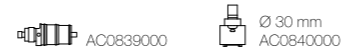
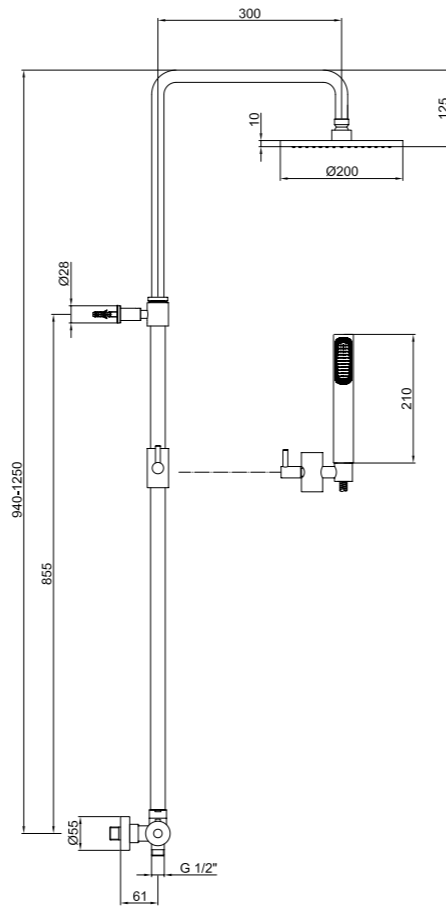

EL980102

BOX PCS. 8

Kg. 3,2



Miscelatore termostatico per doccia esterno, senza flessibile, doccetta e gancio di supporto.

Thermostatic shower mixer without shower set.

Mitigeur thermostatique douche sans garniture de douche.

Thermostat Brausebatterie ohne Brausegarnitur.

Mezclador termostatico externo para ducha, sin tubo flexible,

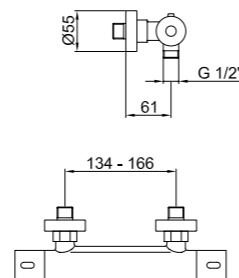

- .015 Cromo / Chrome / Chromé / Verchromt / Cromado
- .560 Nero opaco / Matt black / Noir mat / Matt schwarz / Negro mate
- .345 Acciaio spazzolato / Brushed nickel / Acier brossé / Edelstahl Optik / Acero cepillado

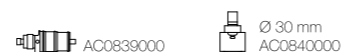

EL880101

BOX PCS. 12

Kg. 1,1



Miscelatore monocomando per doccia incasso, con piastra, senza flessibile, doccetta e gancio.

Concealed single lever shower mixer with cover plate, without shower set.

Mitigeur de douche à encastrer avec rosace, sans garniture de douche.

Einhebelmischer Unterputz-Brausebatterie, mit Rosette, ohne Brausegarnitur.

Monomando empotrable para ducha, con placa, sin tubo flexible, ducha ni gancho.

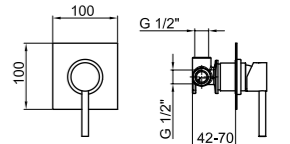

- .015 Cromo / Chrome / Chromé / Verchromt / Cromado
- .560 Nero opaco / Matt black / Noir mat / Matt schwarz / Negro mate
- .345 Acciaio spazzolato / Brushed nickel / Acier brossé / Edelstahl Optik / Acero cepillado



EL860512

BOX PCS. 12

Kg. 3,2



Miscelatore monocomando per vasca incasso, con deviatore, piastra orizzontale; con flessibile doccetta e gancio di supporto.

Concealed single lever bath mixer with diverter, horizontal cover plate, with shower set.

Mitigeur bain-douche à encastrer avec inverseur, rosace horizontale, avec garniture de douche.

Einhebelmischer Unterputz-Badebatterie mit Umstellung, waagerechte Rosette, mit Brausegarnitur.

Monomando empotrable para bañera, con desviador, placa horizontal, con flexible, ducha ni gancho de soporte.

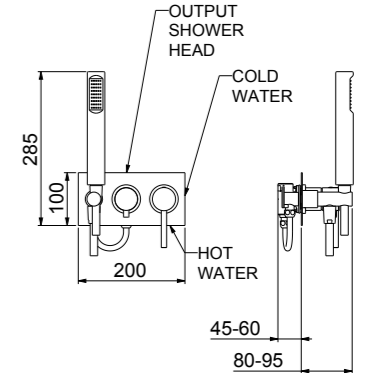

- .015 Cromo / Chrome / Chromé / Verchromt / Cromado
- .560 Nero opaco / Matt black / Noir mat / Matt schwarz / Negro mate
- .345 Acciaio spazzolato / Brushed nickel / Acier brossé / Edelstahl Optik / Acero cepillado



EL870102

BOX PCS. 12

Kg. 2,2



Miscelatore monocomando per doccia esterno; senza flessibile, doccetta e gancio di supporto.

Single lever shower mixer without shower set.

Mitigeur de douche sans garniture de douche.

Einhebelmischer Brausebatterie ohne Brausegarnitur.

Monomando externo para ducha, sin tubo flexible, ducha ni gancho de soporte.

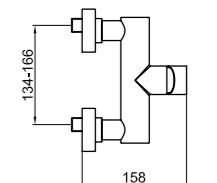
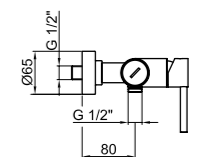

- .015 Cromo / Chrome / Chromé / Verchromt / Cromado
- .560 Nero opaco / Matt black / Noir mat / Matt schwarz / Negro mate
- .345 Acciaio spazzolato / Brushed nickel / Acier brossé / Edelstahl Optik / Acero cepillado

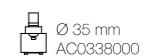

EL971302

BOX PCS. 2

 Kg. 6

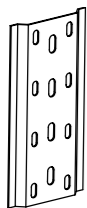

Termostatico incasso a parete alte portate con 1 via.

Thermostatic concealed high flow-rate mixer with 1 way diverter.

Mitigeur thermostatique haut-débit à encastrer avec 1 voies.

Thermostat Unterputz HD Mischer mit 1 Wegeumsteller.

Termostático empotrable alto caudal 1 vía.

.015 Cromo / Chrome / Chromé / Verchromt / Cromado

.560 Nero opaco / Matt black / Noir mat / Matt schwarz / Negro mate

.345 Acciaio spazzolato / Brushed nickel / Acier brossé / Edelstahl Optik / Acero cepillado

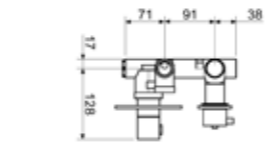
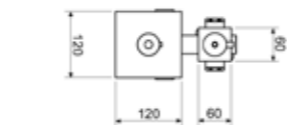
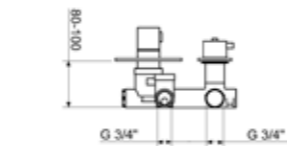

EL971402

BOX PCS. 2

 Kg. 6,5

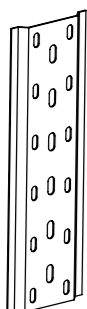

Termostatico incasso a parete alte portate con 2 vie.

Thermostatic concealed high flow-rate mixer with 2 ways diverter.

Mitigeur thermostatique haut-débit à encastrer avec 2 voies.

Thermostat Unterputz HD Mischer mit 2 Wegeumsteller.

Termostático empotrable alto caudal 2 vías.

.015 Cromo / Chrome / Chromé / Verchromt / Cromado

.560 Nero opaco / Matt black / Noir mat / Matt schwarz / Negro mate

.345 Acciaio spazzolato / Stainless steel / Acier brossé / Edelstahl Optik / Acero cepillado

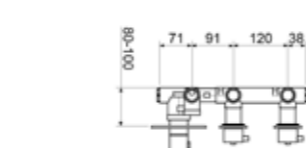
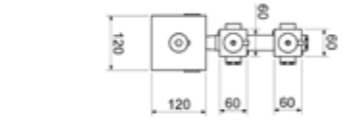
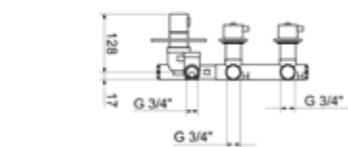

EL971502

BOX PCS. 2

 Kg. 7

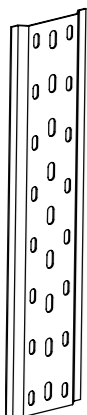

Termostatico incasso a parete alte portate con 3 vie.

Thermostatic concealed high flow-rate mixer with 3 ways diverter.

Mitigeur thermostatique haut-débit à encastrer avec 3 voies.

Thermostat Unterputz HD Mischer mit 3 Wegeumsteller.

Termostático empotrable alto caudal 3 vías.

.015 Cromo / Chrome / Chromé / Verchromt / Cromado

.560 Nero opaco / Matt black / Noir mat / Matt schwarz / Negro mate

.345 Acciaio spazzolato / Brushed nickel / Acier brossé / Edelstahl Optik / Acero cepillado

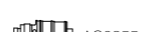
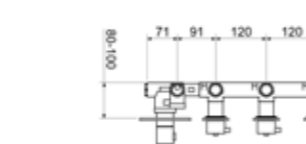
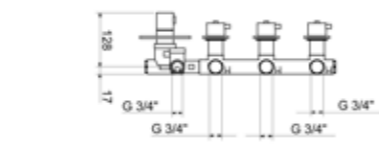

EL690101 1/2"

EL690102 3/4"

BOX PCS. 12

 Kg. 1,0



Rubinetto di arresto ad incasso; attacco da 1/2"-3/4"; venduto singolo.

Stop cock 1/2"-3/4" singly sold.

Robinet à encastrer 1/2"-3/4" vendu single.

Unterputzventil 1/2"-3/4" einzeln verkauft.

Llave de paso conexión de 1/2"-3/4", vendido singularmente.

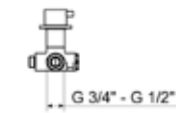

.015 Cromo / Chrome / Chromé / Verchromt / Cromado

.560 Nero opaco / Matt black / Noir mat / Matt schwarz / Negro mate

.345 Acciaio spazzolato / Brushed nickel / Acier brossé / Edelstahl Optik / Acero cepillado

AC0934 1/2"

AC0935 3/4"

BOX PCS. 12

 Kg. 1,0



Parte incasso rubinetto di arresto ad incasso 1/2"-3/4" cartuccia Ø 35.

Concealed part of stop cock 1/2"-3/4", cartridge Ø 35.

Partie Robinet à encastrer 1/2"-3/4", cartouche Ø 35.

Innenteil Unterputzventil 1/2"-3/4", Kartusche Ø 35.

Parte empotrable para llave de paso conexión de 1/2"-3/4", cartucho Ø 35.

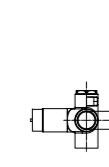

.000 Neutro / Neutral / Neutre / Neutral / Neutral



EL972101

BOX PCS. 12

 Kg. 4

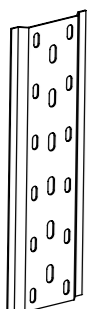

Miscelatore termostatico incasso per doccia.

Thermostatic concealed single lever shower mixer.

Mitigeur de douche à encastrer thermostatique.

Einhebelmischer Thermostat Unterputz-Brausebatterie.

Mezclador termostatico empotrable para ducha.

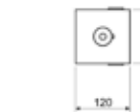
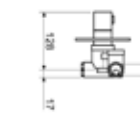

.015 Cromo / Chrome / Chromé / Verchromt / Cromado

.560 Nero opaco / Matt black / Noir mat / Matt schwarz / Negro mate

.345 Acciaio spazzolato / Brushed nickel / Acier brossé / Edelstahl Optik / Acero cepillado



AC0928

BOX PCS. 12

 Kg. 1,9



Parte incasso per termostatico doccia, cartuccia Ø 35.

Concealed part for thermostatic shower mixer, cartridge Ø 35.

Partie encastrée pour mitigeur de douche thermostatique, cartouche Ø 35.

Innenteil Thermostat Unterputz-Brausebatterie, Kartusche Ø 35.

Parte termostática empotrable para ducha, cartucho Ø 35.

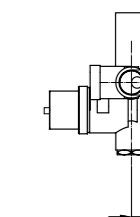

.000 Neutro / Neutral / Neutre / Neutral / Neutral



EL972201

BOX PCS. 12

 Kg. 2,1

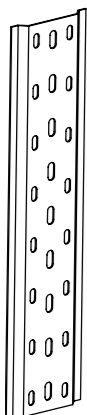

Parte esterna per miscelatore termostatico incasso.

External part for thermostatic shower mixer.

Partie extérieure pour mitigeur thermostatique de douche.

Ausserteil für Thermostat Unterputz-Brausebatterie.

Parte exteriora para mezclador termostático empotrable.

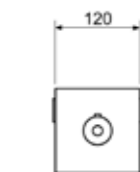

.015 Cromo / Chrome / Chromé / Verchromt / Cromado

.560 Nero opaco / Matt black / Noir mat / Matt schwarz / Negro mate

.345 Acciaio spazzolato / Brushed nickel / Acier brossé / Edelstahl Optik / Acero cepillado



EL870303
BOX PCS. 12

 Kg. 1,8



Miscelatore monocomando a parete con doccia igienica PVC a pulsante.

Single lever mixer with hygienic shower PVC with trigger.

Mitigeur mural avec douche hygiénique PVC à bouton.

EH Wandmischer mit PVC Hygiene Handbrause.

Mezclador de pared con ducha higiénica PVC.

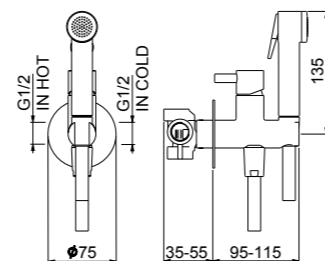

.015 Cromo / Chrome / Chromé / Verchromt / Cromado

.560 Nero opaco / Matt black / Noir mat / Matt schwarz / Negro mate

.345 Acciaio spazzolato / Brushed nickel / Acier brossé / Edelstahl Optik / Acero cepillado

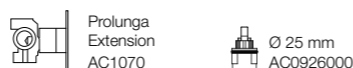

elio

.560
Nero opaco
Mat black
Noir mat
Matt schwarz
Negro mate

EL830101.560

EL830401.560

EL840101.560

EL870301
BOX PCS. 12



Miscelatore monocomando a parete con doccia igienica METAL a pulsante.

Single lever mixer with hygienic shower METAL with trigger.

Mitigeur mural avec douche hygiénique en laiton à bouton.

EH Wandmischer mit aus Messing Hygiene Handbrause.

Mezclador de pared con ducha higiénica de METAL.

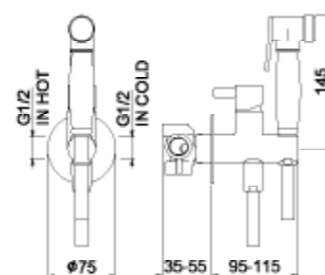

.015 Cromo / Chrome / Chromé / Verchromt / Cromado

.010 Oro / Gold / Doré / Gold / Oro

.065 Bronzato / Bronze / Bronze / Bronze / Bronze

.345 Acciaio spazzolato / Brushed nickel / Acier brossé / Edelstahl Optik / Acero cepillado

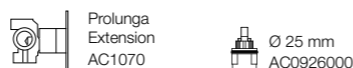

EL830606.560



EL850101.560



EL880101.560

EL870302
BOX PCS. 12

 Kg. 1,8



Miscelatore monocomando a parete con doccia igienica METAL a pulsante.

Single lever mixer with hygienic shower METAL with trigger.

Mitigeur mural avec douche hygiénique en laiton à bouton.

EH Wandmischer mit aus Messing Hygiene Handbrause.

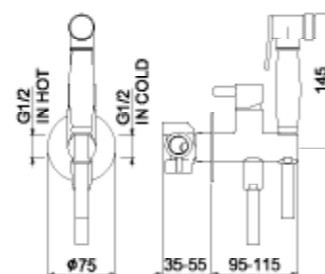

.015 Cromo / Chrome / Chromé / Verchromt / Cromado

.010 Oro / Gold / Doré / Gold / Oro

.065 Bronzato / Bronze / Bronze / Bronze / Bronze

.345 Acciaio spazzolato / Brushed nickel / Acier brossé / Edelstahl Optik / Acero cepillado



EL860101.560



EL851101.560